



General Description

The UV208T uses the Trench technology and design to provide excellent $R_{DS(ON)}$ with low gate charge.

This device is suitable for use in PWM, load switching and general purpose applications.

Features

Enhancement Mode

Enhanced Body diode dv/dt capability

100% Avalanche Tested



SOT23-3 Top view

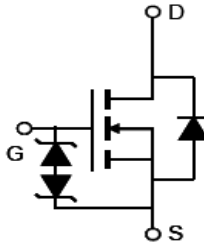

Schematic diagram

Pin 1: Gate 2: Source
3: Drain

V_{DS}	20	V
$R_{DS(on) TYP@V_{GS}=4.5V}$	12.5	m Ω
$R_{DS(on) TYP@V_{GS}=2.5V}$	16.5	m Ω
I_D	6	A
ESD:2500V		

Applications

Power switching application

Hard Switched and High Frequency Circuits

Uninterruptible Power Supply

Package Marking And Ordering Information

Part ID	Package Type	Marking	Tape and Reel information
UV208T	SOT23-3		3000pcs/Reel

Maximum ratings, at $T_j=25^\circ\text{C}$, unless otherwise specified

Symbol	Parameter	Rating	Unit
$V_{(BR)DSS}$	Drain –Source breakdown voltage	20	V
I_D	Continuous drain current	$T_c=25^\circ\text{C}$ 6	A
I_{DM}	Pulse drain current tested ①	$T_c=25^\circ\text{C}$ 22	A
P_D	Maximum power dissipation	$T_c=25^\circ\text{C}$ 1.25	W
V_{GS}	Gate-Source voltage	± 12	V
$T_{STG} T_J$	Storage and operating temperature range	-55 to 175	$^\circ\text{C}$



Thermal Characteristic

Symbol	Parameter	Typical	Unit
R_{QJA}	Thermal Resistance-Junction to Ambient	100	$^{\circ}\text{C}/\text{W}$

Typical Characteristics

Symbol	Parameter	Condition	Min	Type	Max	Unit
Static Electrical Characteristics @ $T_j=25^{\circ}\text{C}$ (unless otherwise stated)						
$V_{(BR)DSS}$	Drain-Source Breakdown Voltage	$V_{GS}=0\text{V}, I_D=250\mu\text{A}$	20			V
I_{DSS}	Zero Gate Voltage Drain Current	$V_{DS}=20\text{V}, V_{GS}=0\text{V}$			1	μA
I_{GSS}	Gate-Body Leakage Current	$V_{GS}=\pm 10\text{V}, V_{DS}=0\text{V}$			± 7	μA
$V_{GS(TH)}$	Gate Threshold Voltage	$V_{DS}=V_{GS}, I_D=250\mu\text{A}$	0.5		1	V
$R_{DS(ON)}$	Drain-Source On-State Resistance ^③	$V_{GS}=4.5\text{V}, I_D=6\text{A}$		12.5	13.5	m Ω
		$V_{GS}=2.5\text{V}, I_D=5\text{A}$		16.5	18.5	m Ω
Dynamic Electrical Characteristics @ $T_j=25^{\circ}\text{C}$ (unless otherwise stated)						
C_{iss}	Input Capacitance	$V_{DS}=10\text{V},$		580		PF
C_{oss}	Output Capacitance	$V_{GS}=0\text{V},$		130		PF
C_{rss}	Reverse Transfer Capacitance	$F=1\text{MHz}$		85		PF
Q_g	Total Gate Charge(4.5V)	$V_{DS}=10\text{V},$		10		nC
Q_{gs}	Gate-Source Charge	$I_D=5\text{A},$		1.6		nC
Q_{gd}	Gate-Drain Charge	$V_{GS}=4.5\text{V}$		3.4		nC
Switching Characteristics						
$t_{d(on)}$	Turn-on Delay time	$V_{DD}=10\text{V}$		8		nS
t_r	Turn-on Rise time	$I_D=6\text{A}$		14.5		nS
$t_{d(off)}$	Turn-off Delay time	$R_G=6\Omega, R_L=3.5\Omega$		33		nS
t_f	Turn-off Fall time	$V_{GS}=4.5\text{V}$		13		nS
Source-Drain Diode Characteristics						
V_{SD}	Forward on voltage	$I_{SD}=1.25\text{A}, V_{GS}=0\text{V}$			1	V

Note:

- ① Repetitive rating; pulse width limited by max, junction temperature.
- ② Limited by T_{jmax} , starting $T_j=25^{\circ}\text{C}$, $L=0.1\text{mH}$, $R_G=6\Omega$, $I_{AS}=1\text{A}$, $V_{GS}=10\text{V}$, Part not recommended for use above this value
- ③ Pulse width $\cong 300\mu\text{s}$; duty cycle $\cong 2\%$
- ④ Package limitation current is 100A



Typical Characteristics

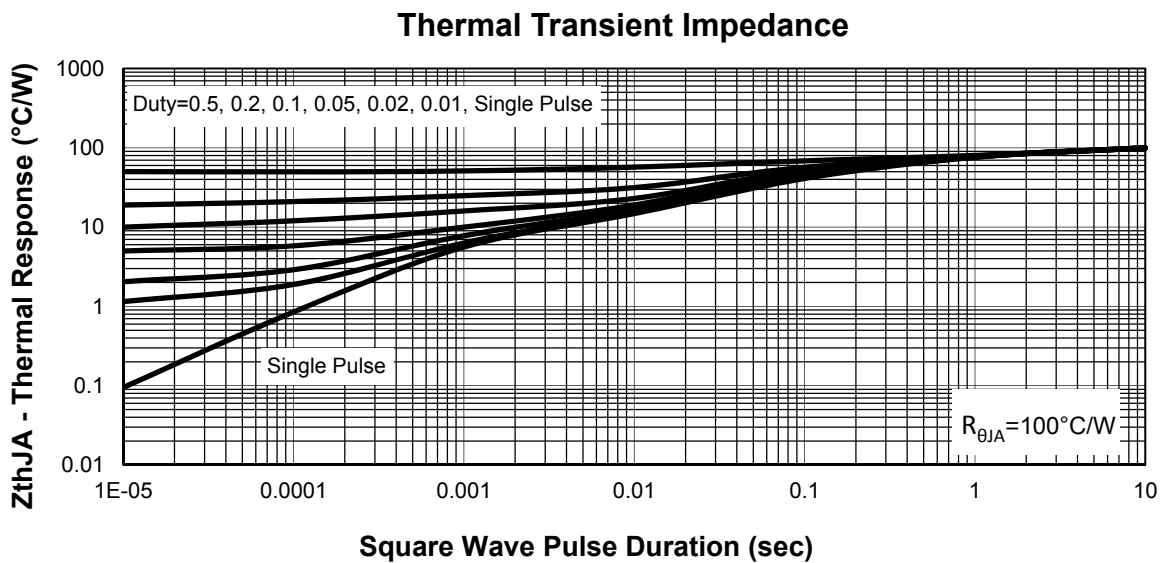
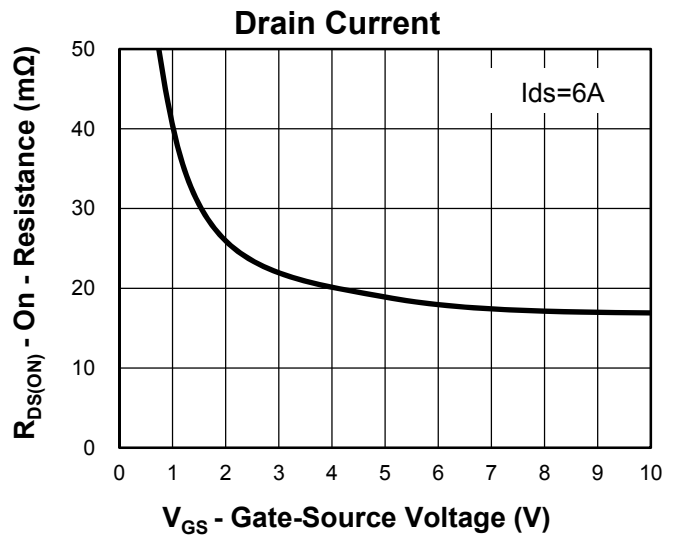
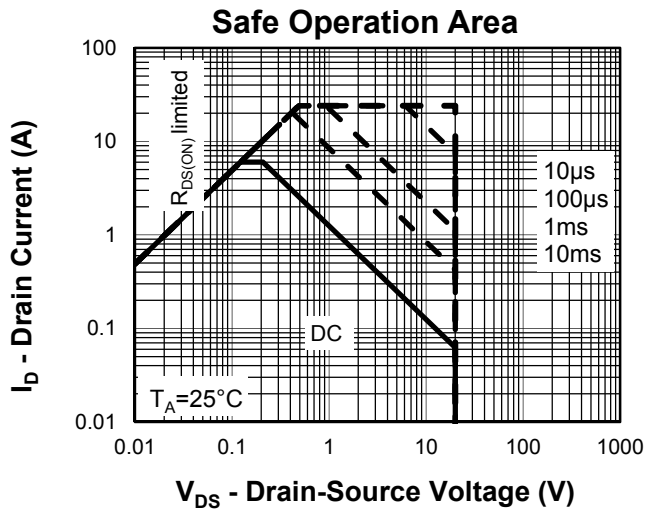
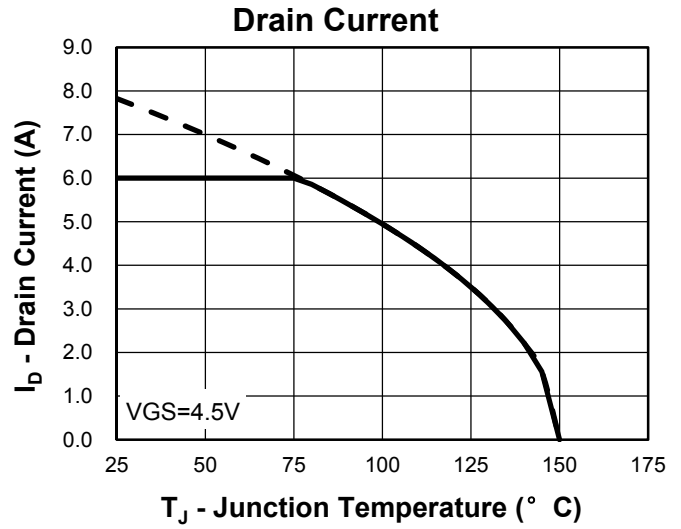
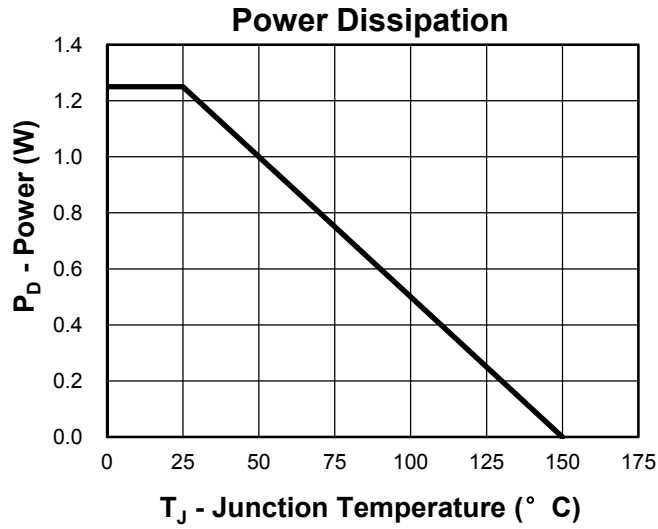



Typical Characteristics

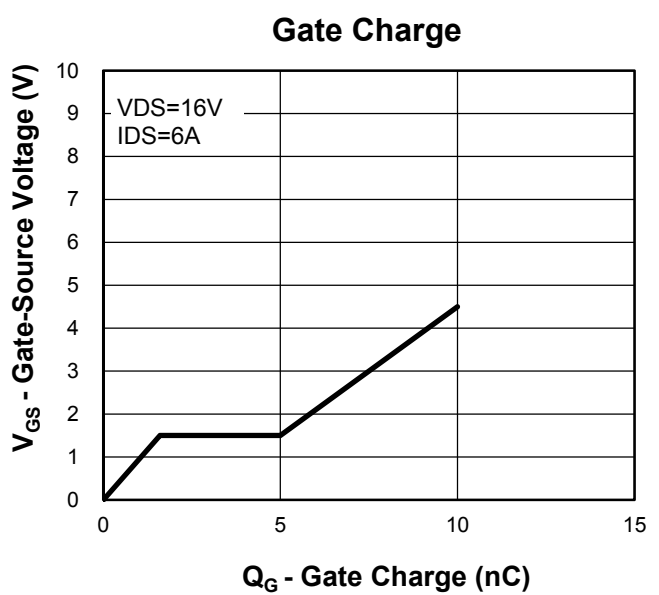
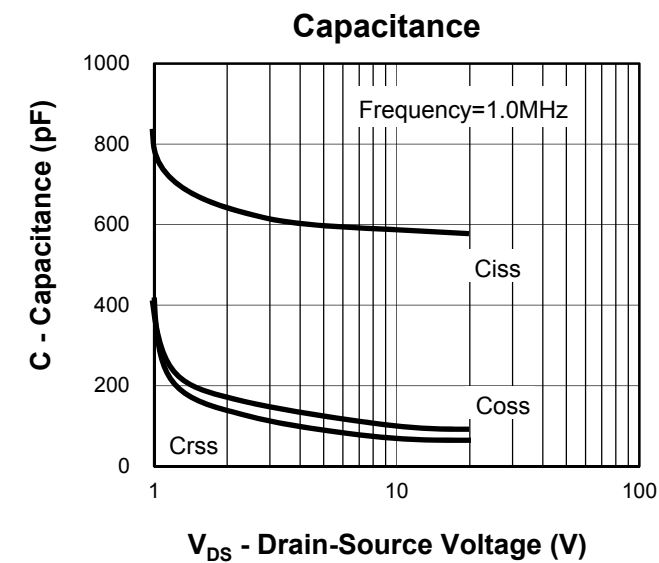
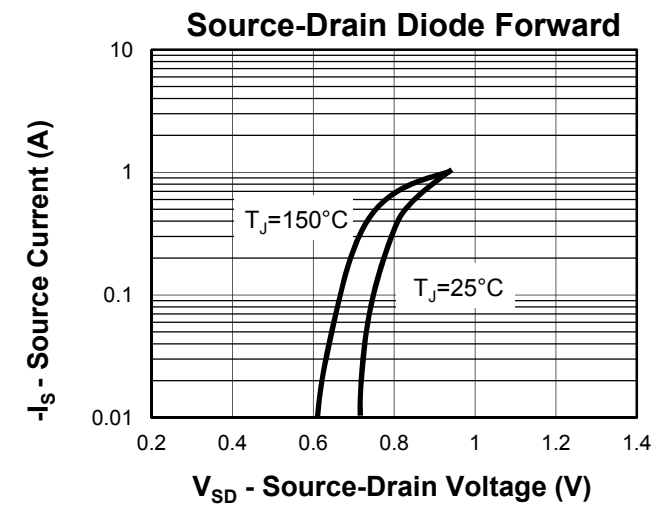
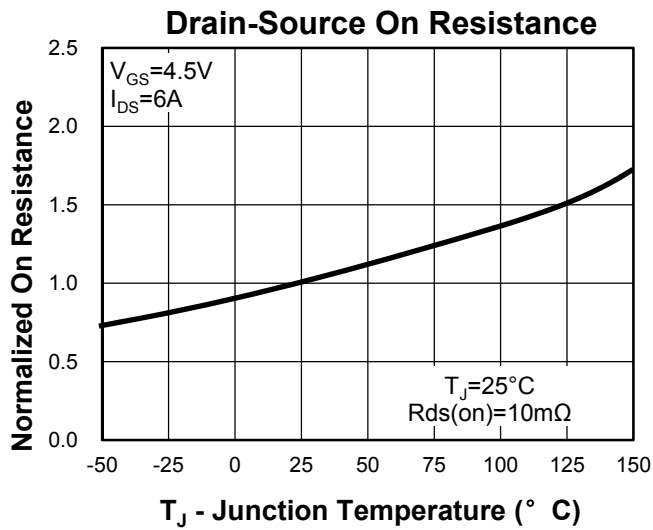
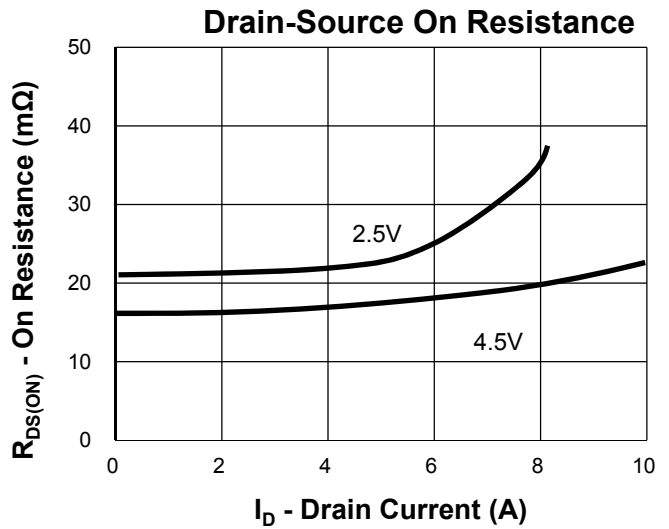
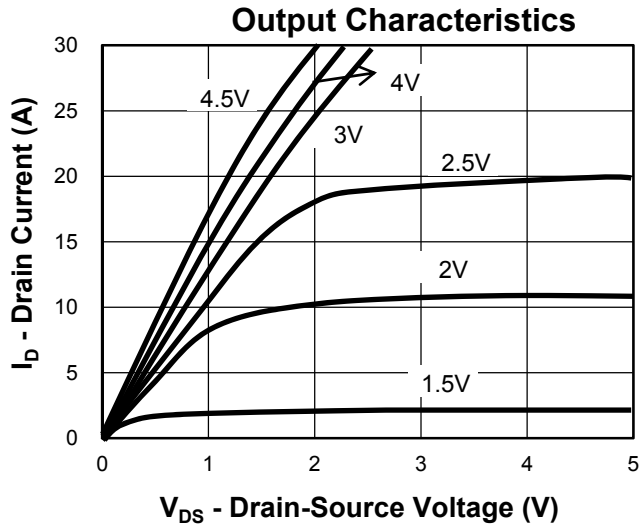



Avalanche Test Circuit and Waveforms

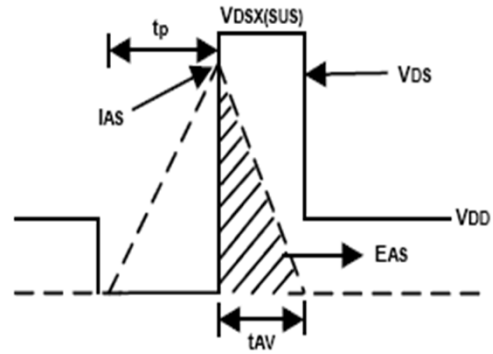
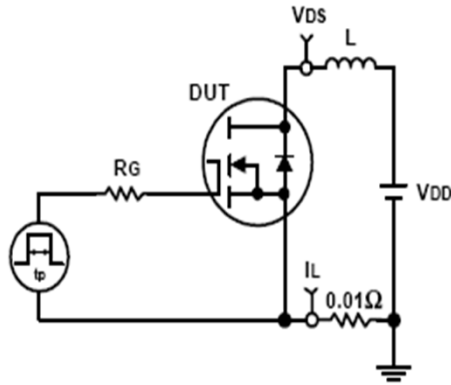

Switching Time Test Circuit and Waveforms

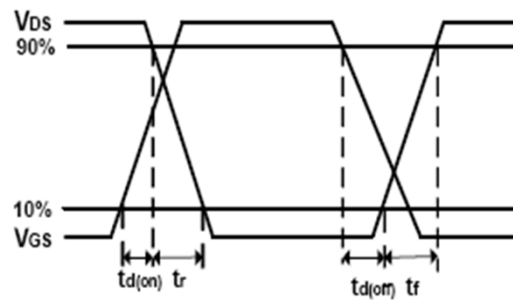
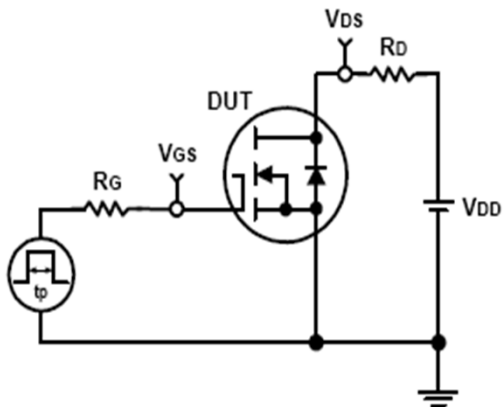



Package Information

SOT23-3

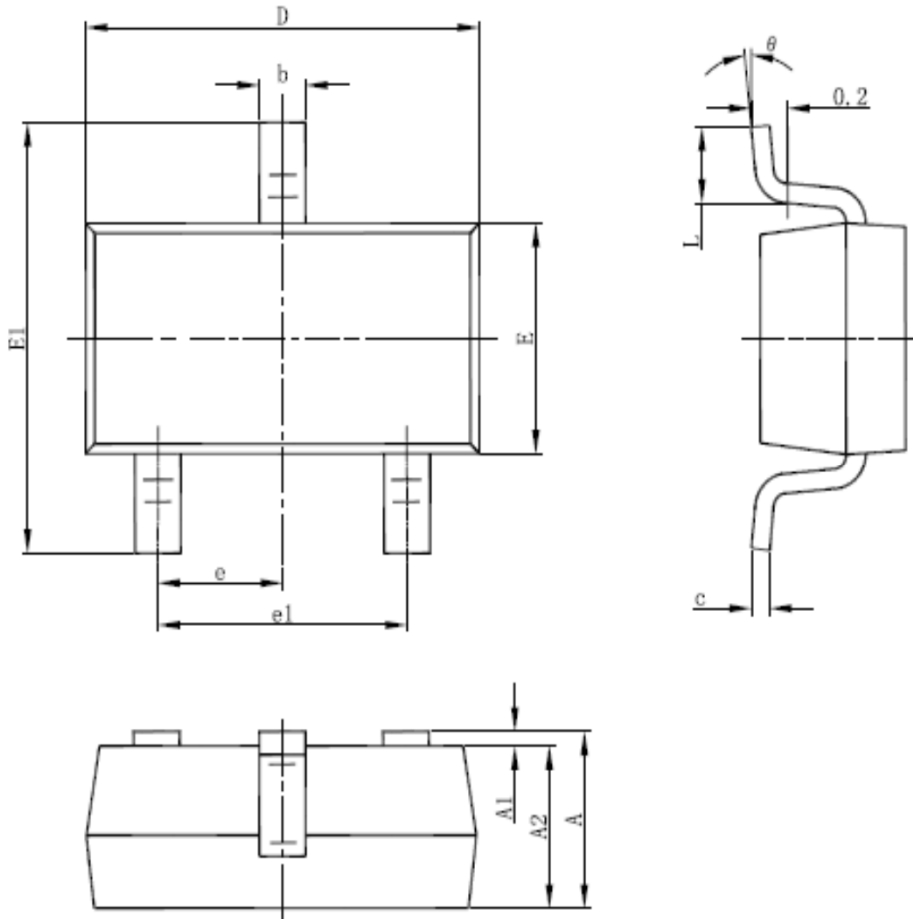

SYMBOL	MM			INCH		
	MIN	NOM	MAX	MIN	NOM	MAX
A	0.950	1.150	1.450	0.037	0.045	0.057
A1	0.000	*	0.150	0.000	*	0.006
A2	0.900	1.100	1.300	0.035	0.043	0.051
b	0.300	0.400	0.500	0.012	0.016	0.020
c	0.080	0.150	0.200	0.003	0.006	0.008
D	2.800	2.925	3.050	0.110	0.115	0.120
E	1.500	1.600	1.750	0.059	0.063	0.069
E1	2.650	2.800	3.000	0.104	0.110	0.118
e	0.950 BSC			0.037 BSC		
e1	1.800	1.900	2.000	0.071	0.075	0.079
L	0.300	0.450	0.600	0.012	0.018	0.024
θ	0°	4°	8°	0°	4°	8°